

Enclosed fork tips

Acid-resistant chassis

Robust and durable

Short and manoeuvrable

Grease nipples on all moving parts



AM I20/I20p

Stainless steel hand pallet truck (2000 kg)

The INOX design of the Jungheinrich hand pallet truck AM is ideal for applications in damp or harsh environments. The advantages of the INOX design is also important where absolute hygiene is required. A choice

of different designs is available dependent on the application.

Decades of Jungheinrich experience in stainless steel hand pallet trucks are reflected

today in reliable and robust trucks. Whether for slaughterhouses, fish processing or for the chemical/pharmaceutical industry – the Jungheinrich stainless steel hand pallet trucks provide the right solution.

AM I20/I20p

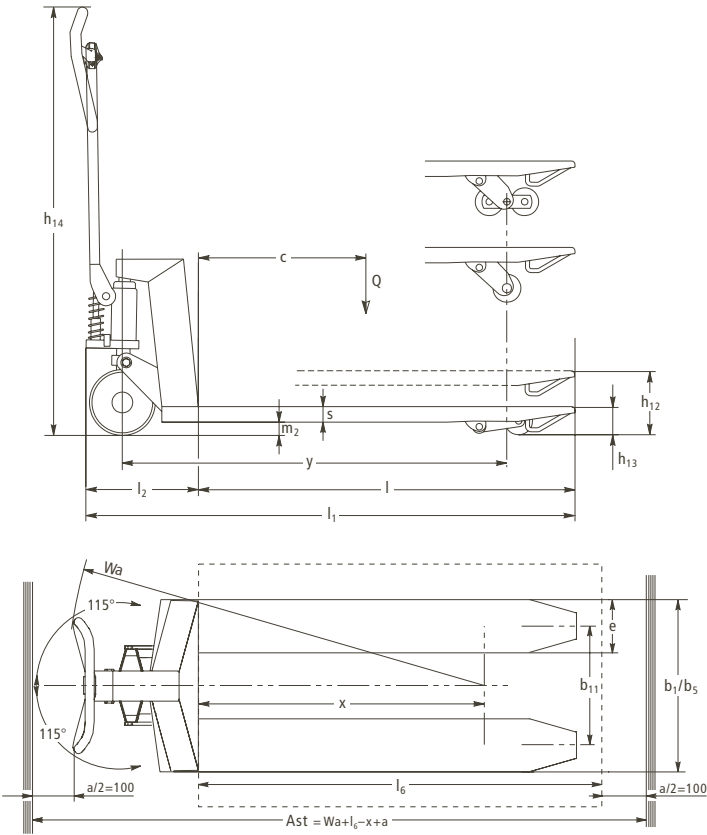

Technical Data in line with VDI 2198 as at: 02/2009

Identification	1.1	Manufacturer (abbreviation)	Jungheinrich	Jungheinrich	Jungheinrich	1.1		
	1.2	Manufacturer's type designation	AM 120/I20p (810 mm)	AM 120/I20p (970 mm)	AM 120/I20p (1140 mm)	1.2		
	1.4	Type of operation	hand	hand	hand	1.4		
	1.5	Load capacity/rated load	Q (t)	2	2	2	1.5	
	1.6	Load centre distance	c (mm)	400	500	600	1.6	
	1.8	Load distance, centre of drive axle to fork	x (mm)	645	805	975	1.8	
	1.9	Wheelbase	y (mm)	875	1035	1170	1.9	
	Weights	2.1	Service weight	kg	64	66	68	2.1
		2.2	Axle loading, laden front/rear	kg	–	–	1432/636	2.2
2.3		Axle loading, unladen front/rear	kg	–	–	47/21	2.3	
Wheels, Chassis	3.1	Tyres	N; V	N; V	N; V	3.1		
	3.2	Tyre size, front	200x50	200x50	200x50	3.2		
	3.3	Tyre size, rear	80x90/80x70	80x90/80x70	80x90/80x70	3.3		
	3.5	Wheels, number front/rear (x = driven wheels)	2/2 or 2/4	2/2 or 2/4	2/2 or 2/4	3.5		
	3.6	Track width, front	b ₁₀ (mm)	130	130	130	3.6	
	3.7	Track width, rear	b ₁₁ (mm)	360	360	360	3.7	
	Basic Dimensions	4.4	Lift height	h ₃ (mm)	115	115	115	4.4
4.9		Height of tiller in drive position min./max.	h ₁₄ (mm)	1220	1220	1220	4.9	
4.14		Standing height, elevated	h ₁₂ (mm)	200	200	200	4.14	
4.15		Lowered height	h ₁₃ (mm)	85	85	85	4.15	
4.19		Overall length	l ₁ (mm)	1150	1310	1480	4.19	
4.20		Length to face of forks	l ₂ (mm)	340	340	340	4.20	
4.22		Fork dimensions	s/e/l (mm)	45x160x810	45x160x970	45x160x1140	4.22	
4.25		Width over forks	b ₅ (mm)	520/680	520/680	520/680	4.25	
4.32		Ground clearance, centre of wheelbase	m ₂ (mm)	38	38	38	4.32	
4.33		Aisle width for pallets 1000x1200 crossways	Ast (mm)	1610	1610	1610	4.33	
4.34		Aisle width for pallets 800x1200 lengthways	Ast (mm)	1810	1810	1810	4.34	
4.35	Turning radius	Wa (mm)	1000	1000	1000	4.35		
Performance Data	5.3	Lowering speed, laden/unladen	m/s	0.09/0.04	0.09/0.04	0.09/0.04	5.3	

Make use of the advantages



Handle

Easy to use

The "easy to operate" handle is equally suitable for left- or right-handed operators. The special lowering valve allows the loads to be lowered with particular sensitivity.

Optimum hygiene

The enclosed fork tips ensure that splatters of dirt cannot reach the load. Freely accessible or completely enclosed openings facilitate effective cleaning with no "hiding places for bacteria". Grease nipples on all moving parts and lubricants suitable for foodstuff (class H1 and H2) are used as standard.

Fast operation

The very short chassis length of 340 mm gives safe and easy operation even in most confined spaces. Easy fork entry and exit is ensured through pallet skids on the fork tips.



Enclosed fork tips

AM I20

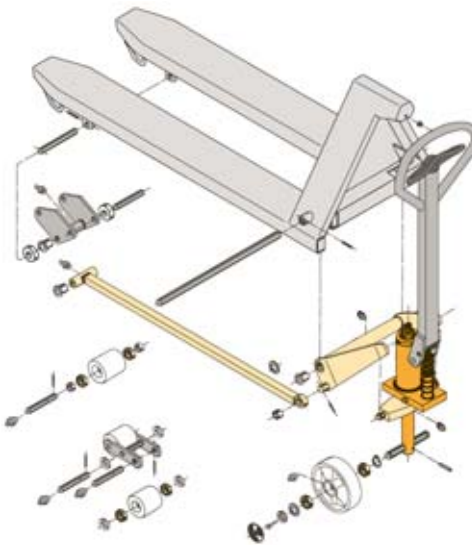

Trucks made 100 % of stainless steel are not always required. Only those components that come in direct contact with food must be made of stainless steel. Some components only need to be moisture repellent. This is the reason why AM I20 components consist of different materials.

- Chassis: acid-resistant stainless steel (AISI 316)
- Tiller: stainless steel (AISI 303/304)
- Pump: electro-galvanised and yellow chromed
- Axle: stainless steel (AISI 303/304)
- Lifting lever: hot-dip galvanised
- Tie rod: hot-dip galvanised
- Support arm lever: stainless steel (AISI 303/304)

AM I20p

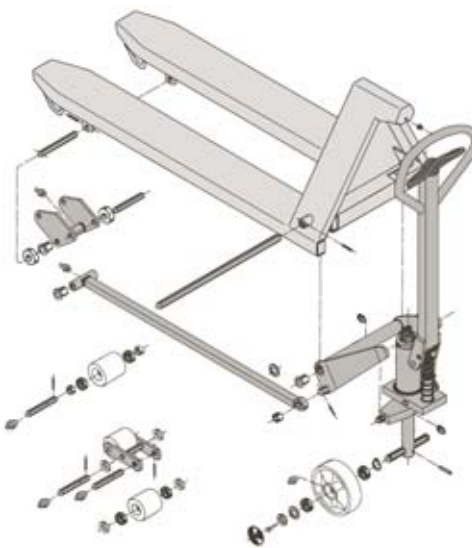

The AM I20p is 100 % protected against rust and was specially designed for applications where hygiene is of utmost importance. Its hydraulics are protected and foreign bodies and water cannot penetrate it.

- Chassis: acid-resistant stainless steel (AISI 316)
- Tiller: stainless steel (AISI 303/304)
- Pump: stainless steel (AISI 303/304)
- Axle: stainless steel (AISI 303/304)
- Lifting lever: stainless steel (AISI 303/304)
- Tie rod: stainless steel (AISI 303/304)
- Support arm lever: stainless steel (AISI 303/304)

Jungheinrich UK Ltd.

Head Office:

Sherbourne House · Sherbourne Drive
Tilbrook · Milton Keynes MK7 8HX
Phone 01908 363100
Fax 01908 363180

info@jungheinrich.co.uk
www.jungheinrich.co.uk



JUNGHEINRICH
Well worthwhile