

**Three phase AC high performance
fork lift truck with sealed drive system**

**Five individually adjustable work
programmes**

**Comfortable operator cab with SOLO-PILOT,
MULTI-PILOT or JetPilot (optional)**

**Jungheinrich Curve Control for optimal
safety when driving and cornering**

**Automatic parking brake system;
no rollback on slopes**

Maintenance free laminated brakes



EFG 425–430

Electric four-wheel fork lift truck (2500 and 3000 kg)

The use of innovative 3 phase technology opens up new opportunities and offers numerous advantages for electric fork truck owners.

- Excellent performance in acceleration, travel and lift speeds ensure the highest throughput.
- Optimal efficiency and energy reclamation offer longer working hours.
- Precisely controllable and wear free regenerative braking. Energy is returned to the battery upon release of the accelerator.
- Maintenance and wear free 3 phase AC motors (without carbon brushes) sealed and protected to IP 54.

This means faster work processing with significantly longer work cycles per battery charge. Lower daily operating costs together with reduced maintenance requirements, guarantee outstanding economy.

Superior travel and lift speeds, as well as, outstanding performance and gradeability offer similar handling to that of diesel and LPG fork lift trucks.

The construction and encasement of the motor make these vehicles suitable for inside or out-

side applications and even in demanding heavy dust, chemical and damp environments, the reliability and lifetime of the motors will not be impaired, therefore allowing the technology to be deployed almost anywhere. Emission-free operation benefits the working environment and the low energy consumption reduces operating costs.

EFG 425-430

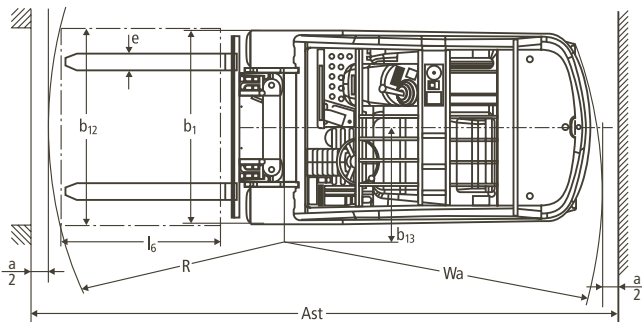
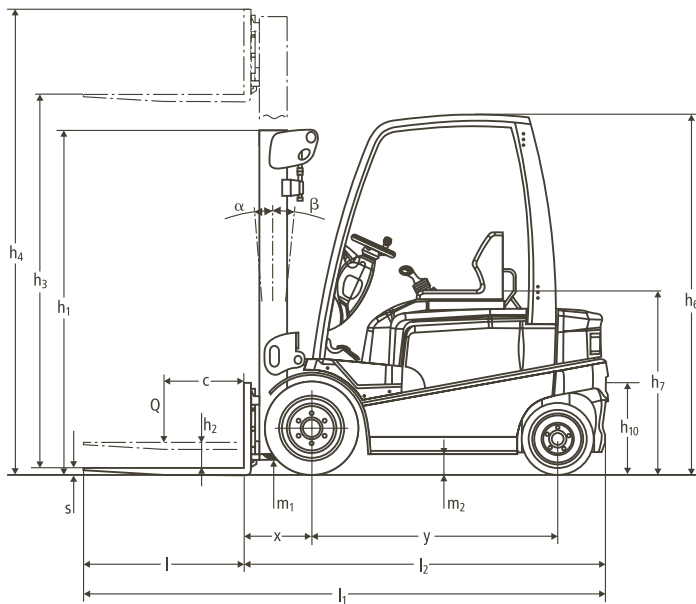

Capacity

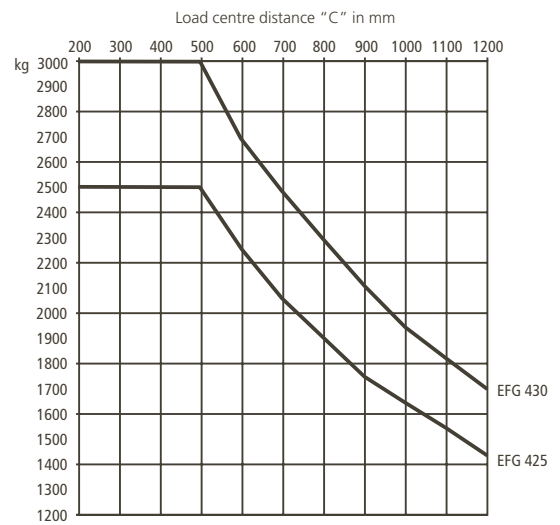

Mast table EFG 425-430							Capacity table (kg) c = 500 mm		
Designation	Lift height h ₃ mm	Free lift h ₂ mm		Closed mast height h ₁ mm	Extended mast height h ₄ mm		Tilt forward/ backward α/β (°)	without sideshift, single SE tyres	
		EFG 425	EFG 430		EFG 425	EFG 430		EFG 425	EFG 430
Two-stage ZT	2900	150	150	2115	3510	3620	6/8	2500	3000
	3100	150	150	2215	3710	3820	6/8	2500	3000
	3300	150	150	2315	3910	4020	6/8	2500	3000
	3500	150	150	2415	4110	4220	6/8	2500	3000
	3700	150	150	2515	4310	4420	6/8	2500	3000
	4000	150	150	2665	4610	4720	6/8	2500	3000
	4300	150	150	2865	4910	5020	6/8	2500	3000
	4500	150	150	2965	5110	5220	6/8	2500	3000
	4700	150	150	3065	5310	5420	6/5	2450	2900
	5000	150	150	3215	5610	5720	6/5	2400	2800
5500	150	150	3515	6110	6220	6/5	2200	2550	
5800	150	150	3665	6410	6520	6/5	2050	2400	
Two-stage ZZ	2900	1480	1380	2080	3500	3600	6/8	2500	3000
	3100	1580	1480	2180	3700	3800	6/8	2500	3000
	3300	1680	1580	2280	3900	4000	6/8	2500	3000
	3500	1780	1680	2380	4100	4200	6/8	2500	3000
	3700	1880	1780	2480	4300	4400	6/8	2500	3000
	4000	2030	1930	2630	4600	4700	6/8	2500	3000
	4300	2230	2130	2830	4900	5000	6/8	2500	3000
4500	2330	2230	2930	5100	5200	6/8	2300	3000	
Three-stage DZ	4400	1480	1380	2080	5000	5100	6/8	2500	3000
	4700	1580	1480	2180	5300	5400	6/5	2450	2900
	5000	1680	1580	2280	5600	5700	6/5	2400	2800
	5500	1880	1780	2480	6100	6200	6/5	2150	2500
	6000	2080	1980	2680	6600	6700	6/5	1900	2200
	6500	2280	2180	2880	7100	7200	6/3	1700	2000
	7000	2480	2380	3080	7600	7700	6/3	1500	1800

Technical Data in line with VDI 2198 as at: 04/2008

		Jungheinrich		Jungheinrich		Jungheinrich					
		EFG 425k	EFG 425	EFG 425ks	EFG 425s	EFG 430					
Identification	1.1	Manufacturer (abbreviation)		Jungheinrich		Jungheinrich	1.1				
	1.2	Manufacturer's type designation		EFG 425k	EFG 425	EFG 425ks	EFG 425s	EFG 430	1.2		
	1.3	Drive		electric		electric		electric	1.3		
	1.4	Type of operation		seated		seated		seated	1.4		
	1.5	Load capacity/rated load	Q (t)	2.5		2.5		3	1.5		
	1.6	Load centre distance	c (mm)	500		500		500	1.6		
	1.8	Load distance, centre of drive axle to fork	x (mm)	425 ¹⁾		425 ¹⁾		430 ²⁾	1.8		
	1.9	Wheelbase	y (mm)	1537	1681	1537	1681	1681	1.9		
	Weights	2.1	Service weight incl. battery (see line 6.5)		4600	4750	4600	4750	5100	2.1	
2.2		Axle loading, laden front/rear		6300/800	6400/850	6300/800	6400/850	7250/850	2.2		
2.3		Axle loading, unladen front/rear		2300/2300	2530/2220	2300/2300	2530/2220	2600/2500	2.3		
Wheels, Chassis	3.1	Tyres		SE		SE		SE	3.1		
	3.2	Tyre size, front (∅ x width)		23x9-10		23x9-10		23x10-12	3.2		
	3.3	Tyre size, rear (∅ x width)		18x7-8		18x7-8		18x7-8	3.3		
	3.5	Wheels, number front/rear (x = driven wheels)		2x/2		2x/2		2x/2	3.5		
	3.6	Track width, front	b ₁₀ (mm)	990		990		956	3.6		
	3.7	Track width, rear	b ₁₁ (mm)	920		920		920	3.7		
	Basic Dimensions	4.1	Mast/fork carriage tilt forward/backward		α/β (°)		6/8		6/8	4.1	
4.2		Lowered mast height		h ₁ (mm)		2215		2215	4.2		
4.3		Free lift		h ₂ (mm)		150		150	4.3		
4.4		Lift height		h ₃ (mm)		3100		3100	4.4		
4.5		Extended mast height		h ₄ (mm)		3710		3820	4.5		
4.7		Overhead load guard (cab + 15 mm) height		h ₆ (mm)		2215		2215	4.7		
4.8		Seat height/standing height		h ₇ (mm)		1060		1060	4.8		
4.12		Coupling height		h ₁₀ (mm)		390/550		390/550	4.12		
4.19		Overall length		l ₁ (mm)		3428	3572	3577	4.19		
4.20		Length to face of forks		l ₂ (mm)		2278	2422	2427	4.20		
4.21		Overall width		b ₁ /b ₂ (mm)		1196/-		1196/-	4.21		
4.22		Fork dimensions		s/e/l (mm)		40/120/1150		45/125/1150	4.22		
4.23		Fork carriage ISO 2328, class/type A, B		ISO 2A		ISO 2A		ISO 3A	4.23		
4.24		Fork carriage width		b ₃ (mm)		1120		1120	4.24		
4.31		Ground clearance, laden, under mast		m ₁ (mm)		110		110	4.31		
4.32		Ground clearance, centre of wheelbase		m ₂ (mm)		125		125	4.32		
4.33		Aisle width for pallets 1000x1200 crossways		Ast (mm)		3675	3825	3830	4.33		
4.34		Aisle width for pallets 800x1200 lengthways		Ast (mm)		3875	4025	4030	4.34		
4.35		Turning radius		Wa (mm)		2050	2200	2200	4.35		
4.36	Smallest pivot point distance		b ₁₃ (mm)		650	695	695	4.36			
Performance Data	5.1	Travel speed, laden/unladen		km/h		17/18	17/17	20/20	20/20	5.1	
	5.2	Lift speed, laden/unladen		m/s		0.44/0.54		0.55/0.60	0.50/0.60	5.2	
	5.3	Lowering speed, laden/unladen		m/s		0.58/0.56		0.58/0.56	0.58/0.56	5.3	
	5.5	Drawbar pull, laden/unladen S ₂ 60 min		N		3600/4000	3500/3900	5200/5500	5100/5500	4800/5300	5.5
	5.6	Max. drawbar pull, laden/unladen S ₂ 5 min		N		12300/12700	12200/12600	14500/15000		14000/14500	5.6
	5.7	Gradient performance, laden/unladen S ₂ 30 min		%		8.5/14	7.5/13	12/19	11/17	10/17	5.7
	5.8	Max. gradient performance, laden/unladen S ₂ 5 min		%		18/29	17/27	21/35	20/32	18/29	5.8
	5.9	Acceleration time, laden/unladen		s		4.3/4.0	4.4/4.1	4.1/3.7		4.2/3.8	5.9
	5.10	Service brake				hydr.		hydr.		hydr.	5.10
	Electric Engine	6.1	Drive motor rating S ₂ 60 min		kW		11		14.5	14.5	6.1
6.2		Lift motor rating at S ₃ 15 %		kW		16		23.5	23.5	6.2	
6.3		Battery acc. to DIN 43531/35/36 A, B, C, no				DIN 43536 A		DIN 43536 A		DIN 43536 A	6.3
6.4		Battery voltage, nominal capacity K _s		V/Ah		80/620	80/775	80/620	80/775	80/775	6.4
6.5		Battery weight		kg		1575	1855	1575	1855	1855	6.5
6.6		Battery dimensions l/w/h		mm		1028/711/784	1028/855/784	1028/711/784	1028/855/784	1028/855/784	6.6
Others	8.1	Type of drive control				impulse/AC		impulse/AC		impulse/AC	8.1
	8.2	Operating pressure for attachments		bar		200		200	200	8.2	
	8.3	Oil volume for attachments		l/min		30		30	30	8.3	
	8.4	Sound level at driver's ear according to EN 12 053		dB(A)		70		71	71	8.4	
	8.5	Tow coupling, type DIN				DIN 15170-H		DIN 15170-H		DIN 15170-H	8.5

1) 452 mm with DZ mast, with integrated sidishift: x = 437 mm (464 mm with DZ mast), with sidishift attachment: x = 483.5 mm (510.5 mm with DZ mast)
2) 457 mm with DZ mast, with integrated sidishift: x = 444 mm (471 mm with DZ mast), with sidishift attachment: x = 502 mm (529 mm with DZ mast)
3) 45 VDI working cycles/h

Make use of the advantages



SOLO-PILOT



MULTI-PILOT



JetPilot

Comfortable operator workplace

The functional and ergonomic operator cabin ensures a relaxing and fatigue free operation of the vehicle during long shifts.

- Low cabin access step, larger, level cabin floor with automotive control pedal layout.
- Adjustable steering column and multi-adjustable comfort seat for optimal seat positioning.
- Floating Cab: protects the cabin from shock and vibration.
- Clear View: mast and fork carriage allow an exceptional view of the load and road.
- Hydraulic Power Steering: effortless and precise control without kick-back.
- The swinging multifunction arm rest (optional) integrates the operational hydraulics (SOLO- or MULTI-PILOT) as well as the Comfort-Display, therefore offering ergonomic control of the vehicle. The arm rest has step-less adjustment, both in height and inclination, a prerequisite for strain free operation.
- Comfortable control of direction and hydraulics with SOLO-PILOT (separate levers) or MULTI-PILOT (optional; all functions combined in one control lever).
- JetPilot (optional) offers high operator comfort by the integration of all travel and hydraulic functions in a steering wheel. The steering wheel concept allows the omission of restricting cabin construction components from the operator knee area and therefore maximises legroom. The automatic return of the steering to the direct-line travel position and the trusted "automobile-feeling" ensures a highly safe and pleasurable driving experience.

Wear free braking – automatic parking brake

Three brake systems ensure safe, comfortable and practically wear free braking.

- Electric motor braking offers freedom from wear and additionally, provides regenerative charging during normal operation of the accelerator.
- Oil filled laminated brake units serve as the safety brake. Wear free and fully encapsulated.
- Electrically activated spring-loaded parking brake. The brake activates automatically when the truck comes to a halt and automatically deactivates, when the truck starts to drive. This system ensures protection against uncontrolled roll forward or backward.

Maintenance free electric motors.

Three phase AC drive, hydraulic and steering motors offer consistency, high performance, less energy consumption and low maintenance:

- High torque for rapid work cycles.
- Up to 15% higher energy efficiency than shunt motors.
- In many applications, one battery charge is sufficient for two work shifts.
- No carbon brushes, no commutator, no maintenance expense.
- Fully enclosed to IP54. Demanding dusty and damp environments do not affect the lifetime of the motor.
- 2 year warranty on all motors.

Safety

Excellent drive dynamics and performance demand a high degree of safety:

- Automatic reduction of travel speed when cornering with Jungheinrich Curve Control.
- No uncontrolled roll-back on inclines and ramps due to an automatic parking brake system.
- wide wheelbase, stable drive characteristics.
- Electronic and hydraulic overload protection.
- Easy and quick access of the emergency cut-off switch.
- Safe and secure transfer of data between control components with CAN-Bus technology.
- A very low centre of gravity and high mounted steering axle ensure the highest of stability.

Intelligent Electronics.

The BoardControl system permanently controls and monitors all functions of the vehicle.

- Pulse control ensures smooth driving, dynamic reversing and precise millimetre positioning of load while at the same time, a minimum of energy consumption.
- Five application programs can be individually modified to ensure optimal performance in any application.
- The diagnostic system monitors all components and handles the storage of service data to allow for quick and cost effective maintenance.
- Comfort Display with digital in-operation hour counter (actual or ED), battery discharge status indicator with lift system shut down, clock, fault code and warning display.
- Electronic steering position indicator.

Jungheinrich UK Ltd.

Head Office:

Sherbourne House · Sherbourne Drive
Tilbrook · Milton Keynes MK7 8HX
Phone 01908 363100
Fax 01908 363180

info@jungheinrich.co.uk
www.jungheinrich.co.uk

Jungheinrich AG
ISO 9001, ISO 14001
Certification of Quality and
Environment Management.



Jungheinrich trucks
conform to the European
Safety Requirements.



JUNGHEINRICH
Well worthwhile