

**Horizontal mover with additional mast lift for comfortable order picking and stacking**

**Powerful maintenance-free AC drive motor**

**Manoeuvrable and compact thanks to its short chassis length**

**For safe use in confined areas, tiller operates in vertical position via crawl speed button**

**On-board charger for easy charging at any mains socket (optional)**



## EJE C20

### Electric powered pedestrian pallet truck (2000 kg)

The EJE C20 is a pedestrian pallet truck which can also be used for order picking and light stacking operations. In addition to the support arm lift the load can be raised to an overall height of 759 mm via a simplex mast contained in the battery compartment. This allows the operator for example to pick goods at a comfortable height.

Light stacking operations, such as stacking half Euro pallets, can be easily undertaken through the separate support arm and mast lift (optional). The support arm

lift capacity is 2000 kg while the mast lift capacity is 700 kg.

There is also a powerful AC drive motor. The efficiency of this motor ensures high speeds and excellent acceleration with low energy consumption ideal for high productivity.

The operator has everything under control at all times, thanks to the low mounted long tiller. This provides a safe distance between the operator and the truck, especially when cornering the EJE C20 never

gets too close to the operator. And if space becomes too tight, the crawl speed button allows safe travel with the tiller in the upright position. One touch of the button is sufficient: the brake is released and the drive speed is automatically reduced.

The re-designed multi-functional tiller arm comes packed with innovations: sealed sensor system (IP 65) for maximum protection, switches with contactor-less electronics for smooth operation, and clearly arranged switches for excellent ergonomics.

# EJE C20

### Vertical battery removal

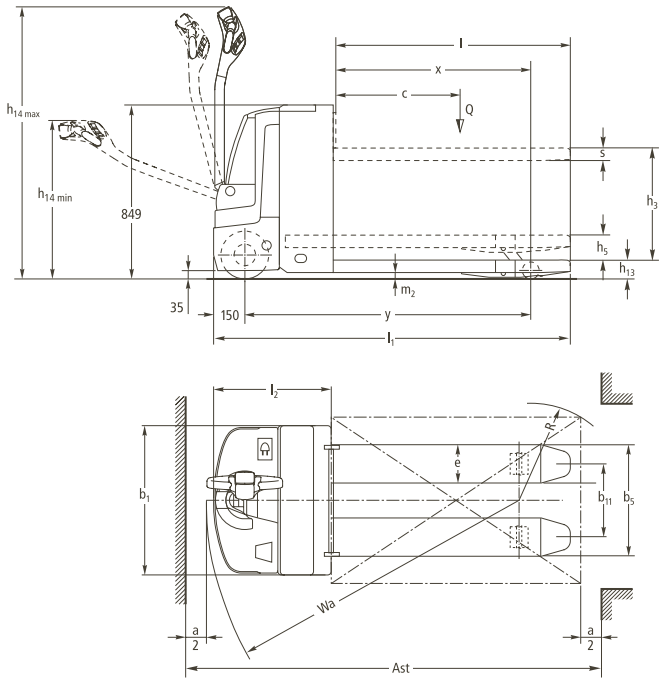

### Sideways battery removal

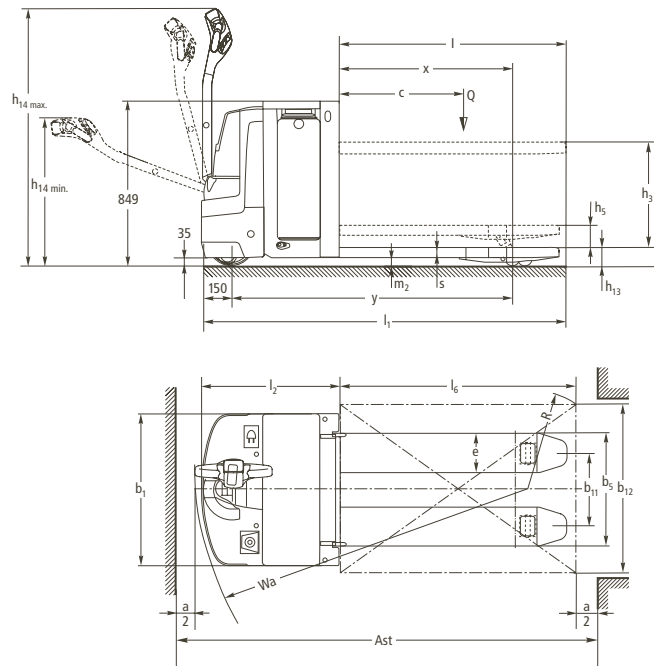

# Technical data in line with VDI 2198 as at: 06/2010

Identification	1.1	Manufacturer (abbreviation)		Jungheinrich	Jungheinrich	1.1
	1.2	Manufacturer's type designation		<b>EJE C20</b>	<b>EJE C20</b>	1.2
					<b>sideways battery removal</b>	
	1.3	Drive		electric	electric	1.3
	1.4	Operator type		pedestrian	pedestrian	1.4
	1.5	Load capacity/rated load	Q (t)	2	2	1.5
		Load capacity mast lift	Q (t)	0.7	0.7	
		Load capacity support arm lift	Q (t)	2	2	
	1.6	Load centre distance	c (mm)	600	600	1.6
1.8	Load distance (Centre of load axle to fork face)	x (mm)	903 <sup>1)</sup>	903 <sup>1)</sup>	1.8	
1.9	Wheelbase	y (mm)	1480 <sup>1)</sup>	1604 <sup>1)</sup>	1.9	
Weights	2.1	Service weight incl. battery (see line 6.5)	kg	555	690	2.1
	2.2	Axle loading, laden front/rear	kg	860/1695	930/1760	2.2
	2.3	Axle loading, unladen front/rear	kg	425/130	514/176	2.3
Wheels, Chassis	3.1	Tyres		PU/PU	PU/PU	3.1
	3.2	Tyre size, front	mm	230x77	230x77	3.2
	3.3	Tyre size, rear	mm	82x100	82x100	3.3
	3.4	Additional wheels (dimensions)		100x40	100x40	3.4
	3.5	Wheels, number front rear (x = driven wheels)		1x + 2/2 or 4	1x + 2/2 or 4	3.5
	3.6	Track width, front	b <sub>10</sub> (mm)	508	508	3.6
	3.7	Track width, rear	b <sub>11</sub> (mm)	343	343	3.7
Basic Dimensions	4.4	Lift (standard mast)	h <sub>1</sub> (mm)	547	547	4.4
	4.6	Initial lift	h <sub>5</sub> (mm)	122	122	4.6
	4.9	Height of tiller in drive position min./max.	h <sub>14</sub> (mm)	797/1313	797/1313	4.9
	4.15	Height, lowered	h <sub>13</sub> (mm)	90	90	4.15
	4.19	Overall length	l <sub>1</sub> (mm)	1734	1858	4.19
	4.20	Length to face of forks	l <sub>2</sub> (mm)	584	708	4.20
	4.21	Overall width	b <sub>1</sub> /b <sub>2</sub> (mm)	720/-	720/-	4.21
	4.22	Fork dimensions	s/e/l (mm)	60/187/1150	60/187/1150	4.22
	4.25	Width across forks	b <sub>5</sub> (mm)	540	540	4.25
	4.32	Ground clearance, centre of wheelbase	m <sub>2</sub> (mm)	30	30	4.32
	4.33	Aisle width for pallets 1000 x 1200 crossways	Ast (mm)	1968 <sup>2)</sup>	2092 <sup>2)</sup>	4.33
4.34	Aisle width for pallets 800 x 1200 lengthways	Ast (mm)	2018 <sup>3)</sup>	2142 <sup>3)</sup>	4.34	
4.35	Turning radius	Wa (mm)	1521 <sup>1)</sup>	1645 <sup>1)</sup>	4.35	
Performance Data	5.1	Travel speed, laden/unladen	km/h	6.0/6.0	6.0/6.0	5.1
	5.2	Lift speed, laden/unladen	m/s	0.12/0.17	0.12/0.17	5.2
	5.3	Lowering speed, laden/unladen	m/s	0.20/0.13	0.20/0.13	5.3
	5.8	Max. gradeability, laden/unladen	%	8/20	8/20	5.8
	5.10	Service brake		electric	electric	5.10
E-Motor	6.1	Drive motor rating S <sub>2</sub> 60 min	kW	1	1	6.1
	6.2	Lift motor rating at S <sub>3</sub> 15%	kW	1.2	1.2	6.2
	6.3	Battery acc. to DIN 43531/35/36 A, B, C, no		no, B	no, B	6.3
	6.4	Battery voltage, nominal capacity K <sub>5</sub>	V/Ah	24/150	24/250	6.4
	6.5	Battery weight	kg	151	215	6.5
	6.6	Energy consumption acc. to VDI cycle	kWh/h	0.44	0.48	6.6
Others	8.1	Type of drive control		AC SpeedControl	AC SpeedControl	8.1
	8.4	Sound level at the driver's ear according to EN 12 053	dB(A)	70	70	8.4

- 1) Load section raised/lowered: + 55 mm  
 2) Load section lowered: + 55 mm; diagonal in accordance with VDI: + 362 mm  
 3) Load section lowered: + 55 mm; diagonal in accordance with VDI: + 202 mm

# Make use of the advantages

## Innovative 3-phase AC technology

Jungheinrich 3-phase AC motors offer greater performance whilst at the same time reducing operating costs over the entire life of the truck:

- High efficiency levels with excellent energy management.
- Powerful acceleration.
- Stepless smooth control of the travel speed via the travel switch.
- Rapid travel direction change without pause.
- No carbon brushes – maintenance-free drive motor.
- Two year warranty on the drive motor.



Back friendly lift height with optional load backrest

## Travel in comfort

The "SpeedControl" electronic control system gives smooth and safe operation:

- The AC motor keeps a constant speed, even on gradients and descents.
- If the EJE C20 starts to roll away on a ramp it brakes automatically.
- A choice of drive parameters (acceleration, top speed, motor brake) for individual matching to each application (optional).
- The operator can choose from 3 travel programmes (optional).

- Energy recovery through regenerative braking on deceleration.
- Very low noise level when travelling.

## Fully informed at all times

Extensive instrument display and setting options allow the operator to monitor the situation at a glance:

- Discharge indicator (3 colour LED) with lift cut-out.
- Adjustable drive parameters through CanDis and CanCode (optional).
- CanDis information display (optional) with additional service hour display and service data storage.
- PIN activation of truck and choice of 3 travel programmes via CanCode (optional).

## Perfect cornering

The hydraulically cushioned support wheels – connected via the patented "ProTrac-Link" torsion bar suspension distributes the forces depending on the situation: evenly on all wheels for normal travel, concentrated on the outer support wheel when cornering.

## Reduced maintenance costs

Service-friendly components ensure a significant long-term reduction in operating costs:

- Maintenance-free AC drive motor with no carbon brushes.
- Easy access to all parts with one-piece front panel with just 2 screws.
- Excellent protection against dust and humidity through enclosure of controller and connectors to IP 54.
- The ProTraLink technology reduces tyre wear when operating on a ramp due to equalising effect of the torsion bar. This bar also keeps the support wheels at the same height and when they go over



In operation in a store

the edge of a loading dock or dock-leveler, unlike a spring loaded wheel they easily drive back into safety.

## Optimum pallet handling

- Enclosed skids on both fork tips for easy entry into empty Euro or perimeter based pallets.
- Separate control of mast and support arm lift to remove semi/quarter pallets from Euro pallets (option).

## Long uptimes

The energy-saving 3-phase AC system combined with a 250 Ah battery capacity ensures long operation times:

- 2 PzB 200 Ah batteries for vertical battery removal.
- Sideways battery removal (optional) for 2 PzB 250 Ah batteries.
- On-board charger (24V/30A for wet cell batteries and maintenance-free batteries) for easy charging at any mains socket (optional).

## Optional equipment

- Writing pad with light
- Load backrest.
- Special key switch for easy brake release.
- Cold store version.

## Jungheinrich UK Ltd.

Head Office:

Sherbourne House · Sherbourne Drive  
Tilbrook · Milton Keynes MK7 8HX  
Phone 01908 363100  
Fax 01908 363180

info@jungheinrich.co.uk  
www.jungheinrich.co.uk



**JUNGHEINRICH**  
Well worthwhile