

**Drive, lift and steering motors
in 3-phase AC technology**

**Improved manoeuvrability
through compact chassis design**

Electric 180° steering

**Smooth hydraulic operation
through SOLO-PILOT control lever**

**High operating safety
with Curve Control**



ETV 110/112/114/116

Electric Reach Truck (1000, 1200, 1400, 1600 kg)

Space-saving construction, excellent performance and comfortable working area – these are the strengths of the Jungheinrich Reach Trucks ETV 110 to 116. The advantages:

- Space-saving through narrow working aisle widths from 2659 mm (according to VDI – when picking up a pallet lengthways). With its slim support arms, the ETV 110/112 can pull a lengthways Euro pallet back between the support arms – despite its compact chassis of only 1120 mm. This creates more room during operation with oncoming traffic in block stacking aisles or in drive-in racking.

- Higher throughput – as well as increased availability – due to 3-phase AC technology on drive, lift and steering motors.
- Motivated and stress-free operators due to efficiency-enhancing ergonomics. The operator is immediately aware of the added comfort: Using the lowered entrance, he comfortably gets into the operator compartment equipped with 3-fold adjustable seat, adjustable armrest as well as a steering wheel adjustable in both horizontal and vertical directions.
- Automatic speed reduction on corners. Curve Control limits maximum travel speed

and acceleration on corners. The danger of a building up process or even tipping over is drastically reduced.

Thus the Jungheinrich series 1 Reach Trucks provide the best solution for cost effective stacking and retrieval at high lift heights and in confined spaces. Be it during the handling of pallets (operating in drive-in racking), in narrow or low areas, or single shift or multi-shift applications – the series 1 Reach Trucks are suited to every application.

ETV 110/112/114/116

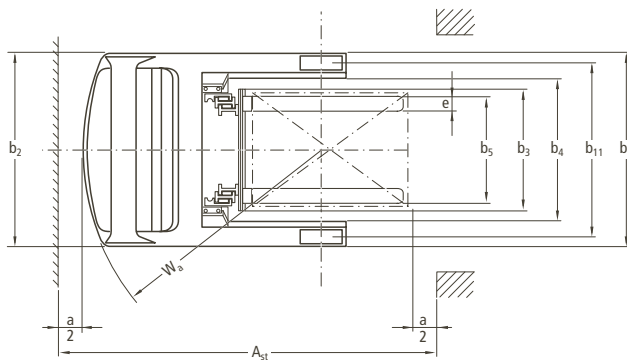
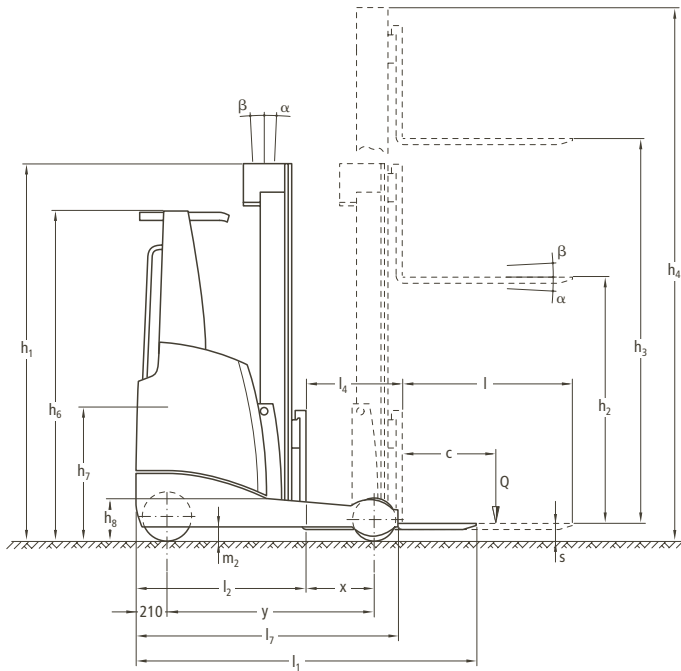

Capacity

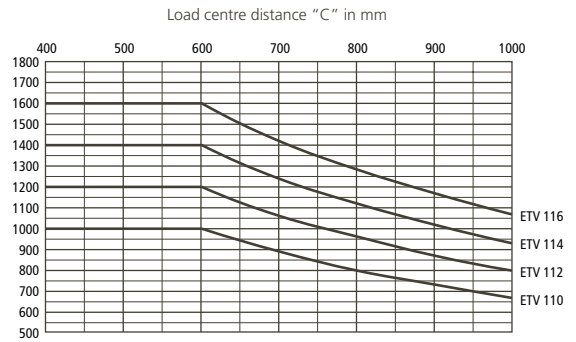

Mast table ETV 110/112/114/116											
Designation	Closed mast height h_1 mm	Lift height h_3 mm	Free lift h_2 mm	Extended mast height h_4 mm	Mast tilt forward/backward α°/β°	Designation	Closed mast height h_1 mm	Lift height h_3 mm	Free lift h_2 mm	Extended mast height h_4 mm	Mast tilt forward/backward α°/β°
Two-stage ZT ETV 110/112	2050	3090	100	3667	2/5	Two-stage ZT ETV 114/116	1950	2900	80	3544	2/5
	2200	3390	100	3967	2/5		2200	3400	80	4044	2/5
	2300	3590	100	4167	2/5		2300	3600	80	4244	2/5
	2400	3790	100	4367	2/5		2500	4000	80	4644	1/5
Three-stage DZ ETV 110/112	2050	4550	1408	5192	2/5	Three-stage DZ ETV 114/116	2700	4400	80	5044	1/5
	2200	5000	1558	5642	1/3		2050	4550	1406	5194	1/5
	2280	5240	1638	5882	1/3		2200	5000	1556	5644	1/5
	2300	5300	1658	5942	1/3		2300	5300	1656	5944	1/5
	2400	5600	1758	6242	1/3		2400	5600	1756	6244	1/3
	2500	5900	1858	6542	1/3		2500	5900	1856	6544	1/3
	2600	6200	1958	6842	1/3		2600	6200	1956	6844	1/3
	2700	6500	2058	7142	1/3		2700	6500	2056	7144	0.5/2
	2800	6800	2158	7442	1/3		2800	6800	2156	7444	0.5/2
	2900	7100	2258	7742	1/3		2900	7100	2256	7744	0.5/2
other lift heights on request						3000	7400	2356	8044	0.5/1	
						3100	7700	2456	8344	0.5/1	
						3200	8000	2556	8644	0.5/1	
						3300	8300	2656	8944	0.5/1	
						3340	8420	2696	9064	0.5/1	
						3440	8720	2796	9364	0.5/1	
						3540	9020	2896	9664	0.5/1	

Technical Data in line with VDI 2198 as at: 10/2009

Identification	1.1	Manufacturer (abbreviation)	Jungheinrich	Jungheinrich	Jungheinrich	Jungheinrich	1.1		
	1.2	Manufacturer's type designation	ETV 110	ETV 112	ETV 114	ETV 116	1.2		
		G = fork; E = integrated sideshift	GE	GE	GE	GE			
	1.3	Drive	electric	electric	electric	electric	1.3		
	1.4	Type of operation	seated	seated	seated	seated	1.4		
	1.5	Load capacity/rated load	Q (t)	1	1.2	1.4	1.6	1.5	
	1.6	Load centre distance	c (mm)	600	600	600	600	1.6	
	1.8	Load distance, centre of drive axle to fork	x (mm)	345 ¹⁾	430 ¹⁾	417 ¹⁾	395 ¹⁾	1.8	
	1.8	Mast pushed forward	x ₁ (mm)	170	170	205	205	1.8	
1.9	Wheelbase	y (mm)	1300	1385	1410	1460	1.9		
Weights	2.1	Service weight incl. battery (see line 6.5)	kg	2560	2580	2950	3070	2.1	
	2.3	Axle loading, unladen front/rear	kg	1587/973	1587/993	1770/1180	1842/1228	2.3	
	2.4	Axle loading, fork advanced, laden front/rear	kg	634/2926	516/3264	522/3828	560/4110	2.4	
	2.5	Axle loading, fork retracted, laden front/rear	kg	1282/2278	1361/2419	1566/2784	1681/2989	2.5	
	Wheels, Chassis	3.1	Tyres	Vulkollan®	Vulkollan®	Vulkollan®	Vulkollan®	3.1	
3.2		Tyre size, front	343x114	343x114	343x114	343x114	3.2		
3.3		Tyre size, rear	230x85	230x85	285x100	285x100	3.3		
3.5		Wheels, number front/rear (x = driven wheels)	1x/2	1x/2	1x/2	1x/2	3.5		
3.6		Track width, front	b ₁₀ (mm)	–	–	–	–	3.6	
3.7		Track width, rear	b ₁₁ (mm)	993	993	1136	1136	3.7	
Basic Dimensions		4.1	Mast/fork carriage tilt forward/backward	α/β (°)	2/5 ²⁾	2/5 ²⁾	1/5 ²⁾	1/5 ²⁾	4.1
	4.2	Lowered mast height	h ₁ (mm)	2300	2300	2300	2300	4.2	
	4.3	Free lift	h ₂ (mm)	1658	1658	1656	1656	4.3	
	4.4	Lift height	h ₃ (mm)	5300	5300	5300	5300	4.4	
	4.5	Extended mast height	h ₄ (mm)	5942	5942	5944	5944	4.5	
	4.7	Overhead load guard (cab) height	h ₆ (mm)	2150	2150	2150	2150	4.7	
	4.8	Seat height/standing height	h ₇ (mm)	960	960	960	960	4.8	
	4.10	Height of wheel arms	h ₈ (mm)	265	265	285 ³⁾	285 ³⁾	4.10	
	4.19	Overall length	l ₁ (mm)	2315 ¹⁾	2315 ¹⁾	2346 ¹⁾	2418 ¹⁾	4.19	
	4.20	Length to face of forks	l ₂ (mm)	1165 ¹⁾	1165 ¹⁾	1196 ¹⁾	1268 ¹⁾	4.20	
	4.21	Overall width	b ₁ /b ₂ (mm)	1120/1120	1120/1120	1270/1270	1270/1270	4.21	
	4.22	Fork dimensions	s/e/l (mm)	40x80x1150	40x80x1150	40x120x1150	40x120x1150	4.22	
	4.23	Fork carriage ISO 2328, class/type A, B		2/B	2/B	2/B	2/B	4.23	
	4.24	Fork carriage width	b ₃ (mm)	800	800	800	800	4.24	
	4.25	Width over forks	b ₅ (mm)	296/677	296/677	335/709	335/709	4.25	
	4.26	Distance between support arms/loading surfaces	b ₄ (mm)	900	900	932	932	4.26	
	4.28	Reach distance	l ₄ (mm)	515 ¹⁾	600 ¹⁾	622 ¹⁾	600 ¹⁾	4.28	
	4.31	Ground clearance, laden, under mast	m ₁ (mm)	85	85	85	85	4.31	
	4.32	Ground clearance, centre of wheelbase	m ₂ (mm)	80	80	80	80	4.32	
4.33	Aisle width for pallets 1000 x 1200 crossways	Ast (mm)	2603/2370 ³⁾	2623/2365 ³⁾	2650/2396 ³⁾	2715/2468 ³⁾	4.33		
4.34	Aisle width for pallets 800 x 1200 lengthways	Ast (mm)	2659/2570 ³⁾	2663/2565 ³⁾	2692/2596 ³⁾	2762/2668 ³⁾	4.34		
4.35	Turning radius	Wa (mm)	1515	1595	1613	1663	4.35		
4.37	Length across wheel arms	l ₇ (mm)	1640	1725	1792	1842	4.37		
Performance Data	5.1	Travel speed, laden/unladen	km/h	11/11 ⁴⁾	11/11 ⁴⁾	10/10 ⁴⁾	10/10 ⁴⁾	5.1	
	5.2	Lift speed, laden/unladen	m/s	0.48/0.70	0.43/0.70	0.37/0.65	0.33/0.60	5.2	
	5.3	Lowering speed, laden/unladen	m/s	0.50/0.50	0.50/0.50	0.50/0.50	0.50/0.50	5.3	
	5.4	Reach speed, laden/unladen	m/s	0.2/0.2 ²⁾	0.2/0.2 ²⁾	0.2/0.2 ²⁾	0.2/0.2 ²⁾	5.4	
	5.7	Gradient performance, laden/unladen	%	7/10	7/10	7/10	7/10	5.7	
	5.8	Max. gradient performance, laden/unladen	%	10/15	10/15	10/15	10/15	5.8	
	5.9	Acceleration time, laden/unladen	s	4.8/4.4	4.9/4.4	5.1/4.8	5.2/4.8	5.9	
	5.10	Service brake		electric	electric	electric	electric	5.10	
	Electric Engine	6.1	Drive motor rating S ₂ 60 min.	kW	6.9	6.9	6.9	6.9	6.1
		6.2	Lift motor rating at S ₃ 15%	kW	10	10	10	10	6.2
6.3		Battery acc. to DIN 43531/35/36 A, B, C, no		B	B	C	C	6.3	
6.4		Battery voltage, nominal capacity K _s	V/Ah	48/280	48/280	48/420	48/420	6.4	
6.5		Battery weight	kg	556	556	750	750	6.5	
Others	8.1	Type of drive control		MOSFET/AC	MOSFET/AC	MOSFET/AC	MOSFET/AC	8.1	
	8.2	Operating pressure for attachments	bar	150	150	150	150	8.2	
	8.3	Oil volume for attachments	l/min	20	20	20	20	8.3	
	8.4	Sound level at driver's ear according to EN 12 053	dB(A)	68	68	68	68	8.4	
1) other battery sizes change these values 2) dependent on mast 3) with ground storage 4) in load direction 10 km/h 5) with load wheel cover +30 mm									

This specification sheet according to VDI regulation 2198 only provides technical values for the standard truck. Non-standard tyres, different masts, additional equipment, etc. could produce other values. Rights reserved for technical changes and improvements.

Make use of the advantages

High performance mast

Jungheinrich masts guarantee maximum safety and storage utilisation to high lift heights. Their strengths:

- Excellent visibility towards the load.
- Integrated sideshift.
- Lowest closed mast height with high lift heights.
- Extremely long service life due to high quality mast profiles.
- High residual capacities up to high lift heights.
- Lift heights up to 9020 mm with mast tilt.



Ergonomic cab

Ergonomic cab

The operator cab provides ideal working conditions for excellent performance and support for the operator. Its strength:

- Comfortable seat with adjustment options (sitting position/backrest/body weight) for every operator.
- Various storage facilities.
- The important operating functions are easily accessible without reaching round.
- Generous space.
- 3-phase AC steering (180° or as an option 360°) with stress-free steering wheel position.
- Horizontal/vertical steering wheel adjustment.



SOLO-PILOT

Effortless operation with SOLO-PILOT

Incorporating the control levers for all hydraulic functions as well as travel direction selection and horn.

- All operating functions are in view.
- Additional attachments, such as fork spreaders (optional), are also easily controlled with the SOLO-PILOT.
- Precise operation through sensitive control of all functions.
- Comfortable working position with adjustable armrest.

Easily read operator display

High quality display of important operating information.

- Travel direction and wheel position indicator.
- 180°/360° steering mode.
- Battery discharge display with residual running time.
- Three adjustable travel programs to suit every requirement.
- Operating hours and time.
- Lift height (optional).

More efficient with 3-phase AC technology

Powerful 3-phase AC technology for drive, lift and steering motors provides a number of advantages compared with traditional direct current motors.

- Powerful acceleration.
- Fast reversing without hesitation.
- High availability through maintenance-free motors without carbon brushes.
- Longer operating times due to energy reclamation on reducing the travel speed.
- 2-year warranty on drive and lift motors.

A chassis width for every application

The correct chassis width for the appropriate application. ETV 110/112 with 1120 mm chassis width for drive-in racking or block stacking aisles. Picking up a Euro pallet lengthways between the support arms is possible. ETV 114/116 with 1270 mm outer chassis width for high capacities to high lift heights.



The correct chassis for every application

Jungheinrich UK Ltd.

Head Office:

Sherbourne House · Sherbourne Drive
Tilbrook · Milton Keynes MK7 8HX
Phone 01908 363100
Fax 01908 363180

info@jungheinrich.co.uk
www.jungheinrich.co.uk



Jungheinrich trucks conform to the European Safety Requirements.

JUNGHEINRICH
Well worthwhile